

# A Compositional Approach to the Stochastic Dynamics of Gene Networks

Luca Cardelli

Microsoft Research

with Ralf Blossey and Andrew Phillips

Concur 2005-08-25

# 50 Years of Molecular Cell Biology

- **Genes are made of DNA**
  - Store digital information as sequences of 4 different nucleotides
  - Direct protein assembly through RNA and the Genetic Code
- **Proteins (>10000) are made of amino acids**
  - Process signals
  - Activate genes
  - Move materials
  - Catalyze reactions to produce substances
  - Control energy production and consumption
- **Bootstrapping still a mystery**
  - DNA, RNA, proteins, membranes are today interdependent. Not clear who came first
  - Separation of tasks happened a long time ago
  - Not understood, not essential

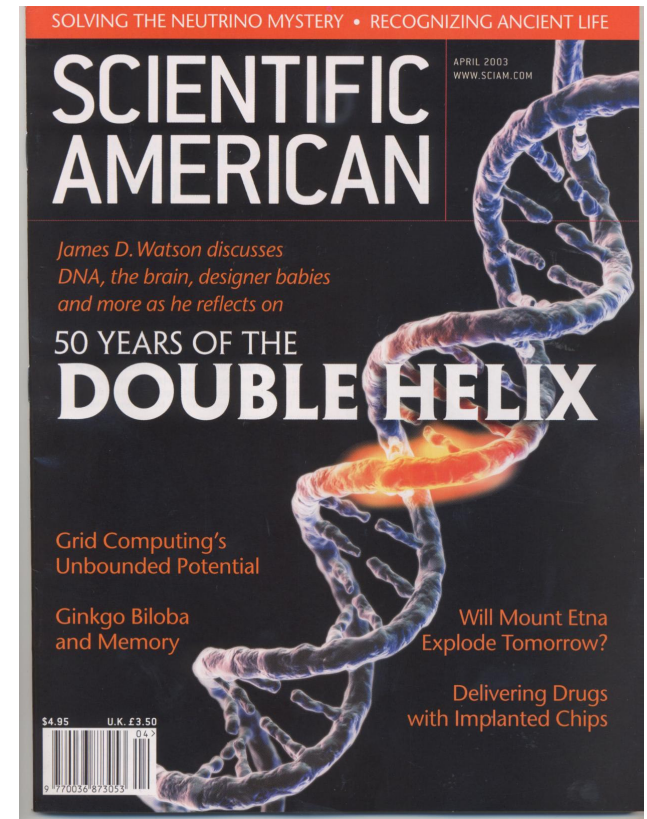

# Towards Systems Biology

- Biologists now understand many of the cellular components
  - A whole team of biologists will typically study a single protein for years
  - **Reductionism: understand the components in order to understand the system**
- But this has not led to understand how "the system" works
  - Behavior comes from **complex patterns of interactions between components**
  - Predictive biology and pharmacology still rare
  - Synthetic biology still unreliable
- **New approach: try to understand "the system"**
  - Experimentally: massive data gathering and data mining (e.g. Genome projects)
  - Conceptually: modeling and analyzing networks (i.e. interactions) of components
- **What kind of a system?**
  - Just beyond the basic chemistry of energy and materials processing...
  - Built right out of digital information (DNA)
  - Based on information processing for both survival and evolution
  - *Highly* concurrent
- **Can we fix it when it breaks?**
  - Really becomes: How is information structured and processed?

# Storing Processes

- Today we represent, store, search, and analyze:

- Gene sequence data
- Protein structure data
- Metabolic network data
- Signaling pathway data
- ...

Cellular Abstractions: Cells as Computation  
Regev&Shapiro NATURE vol 419, 2002-09-26, 343

- How can we represent, store, and analyze *biological processes*?

- Scalable, precise, dynamic, highly structured, maintainable representations for *systems biology*.
- Not just huge lists of chemical reactions or differential equations.

- In computing...

- There are well-established scalable representations of dynamic reactive processes.
- They look more or less like little, mathematically based, programming languages.

# Structural Architecture

## Eukaryotic Cell

(10~100 trillion in human body)

Membranes everywhere

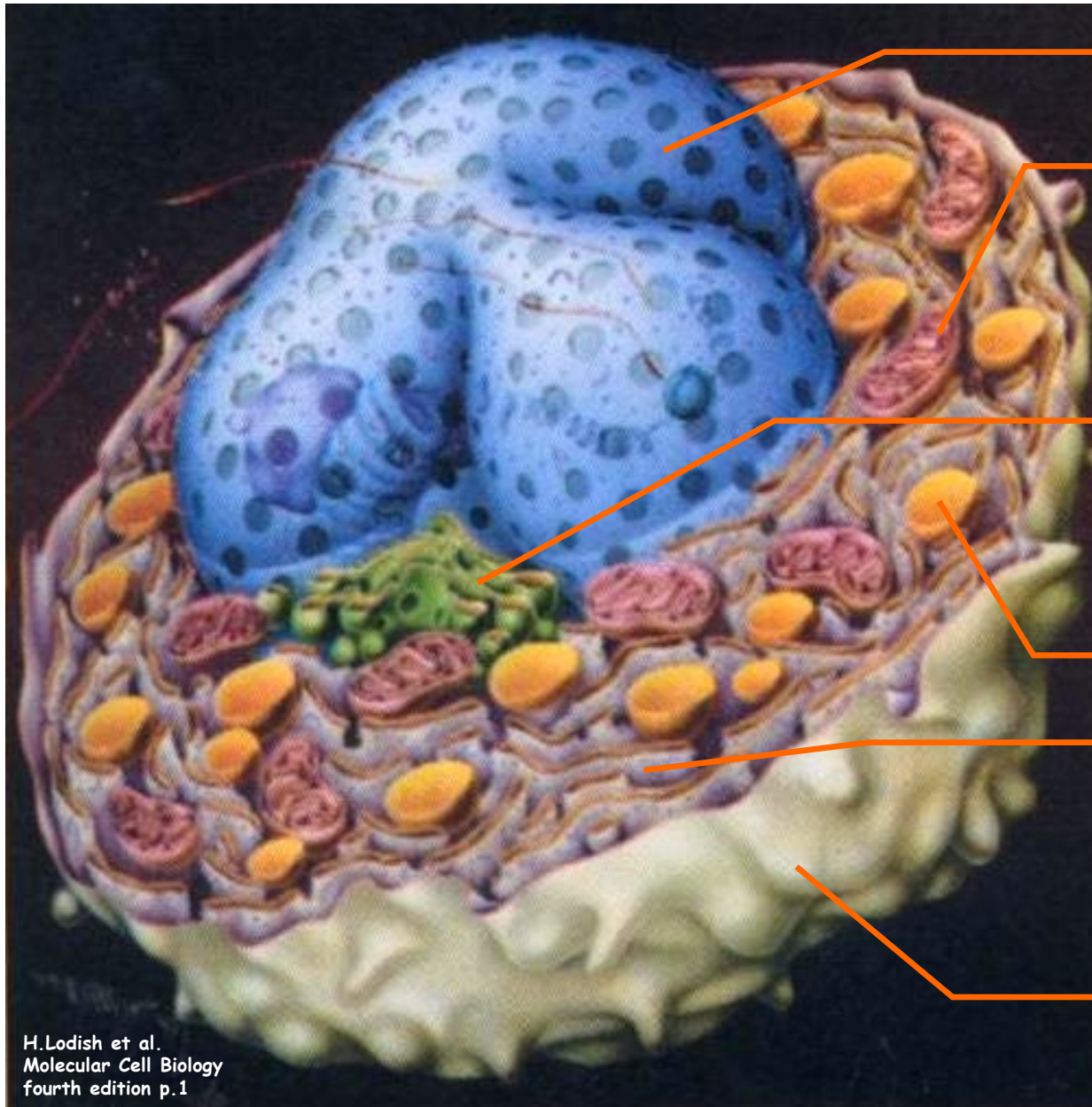

Nuclear membrane

Mitochondria

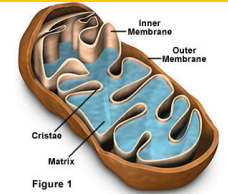

Golgi

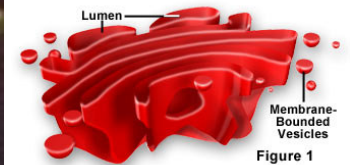

Vesicles

E.R.

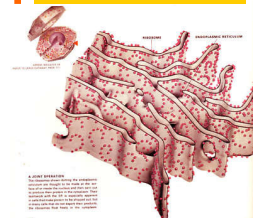

Plasma membrane (<10% of all membranes)



H.Lodish et al.  
Molecular Cell Biology  
fourth edition p.1



# Abstract Machines of Systems Biology

The "hardware" (biochemistry) is fairly well understood.  
 But what is the "software" that runs on these machines?

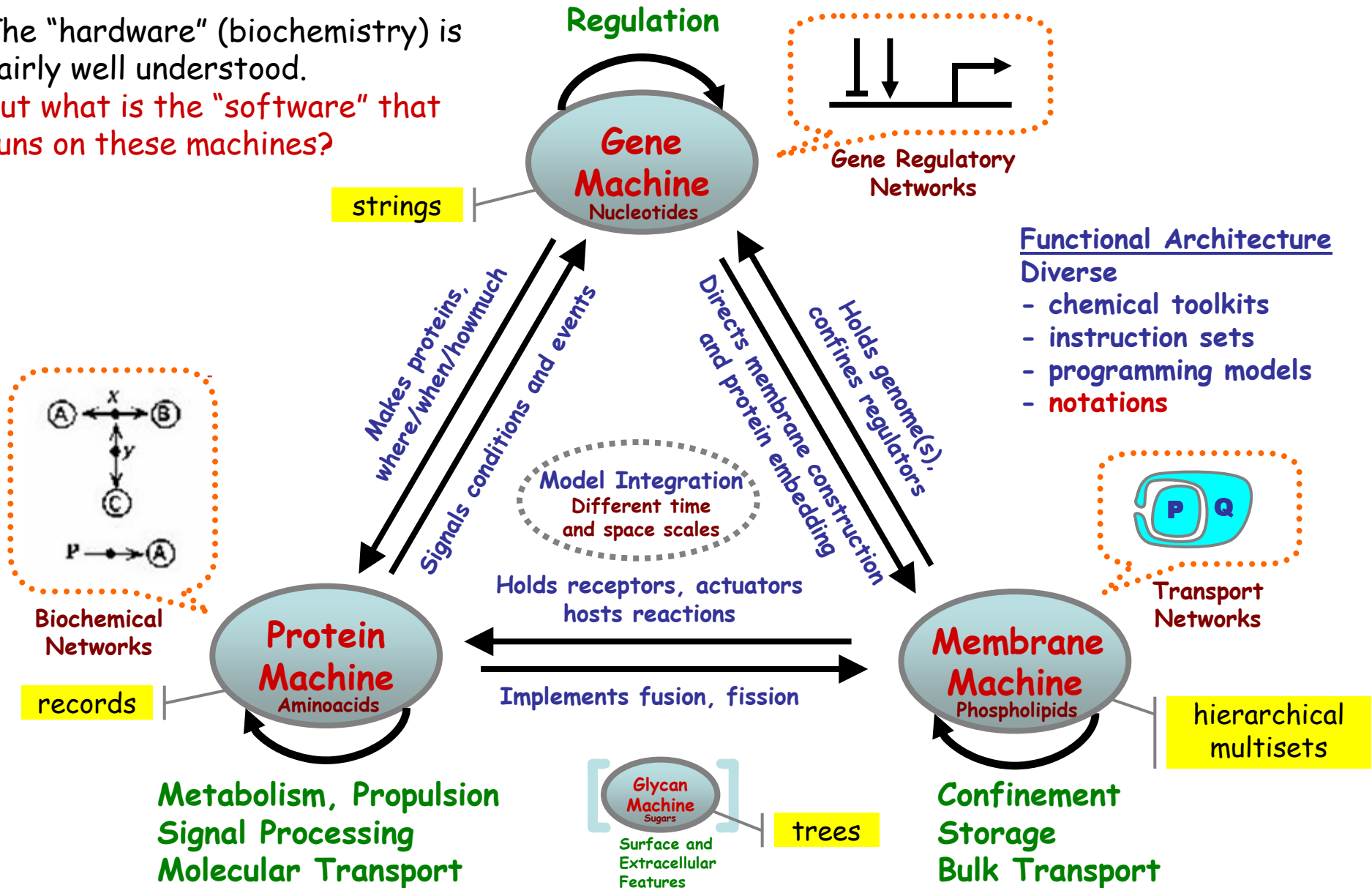

# Abstract Machines of Systems Biology

The "hardware" (biochemistry) is fairly well understood.  
 But what is the "software" that runs on these machines?

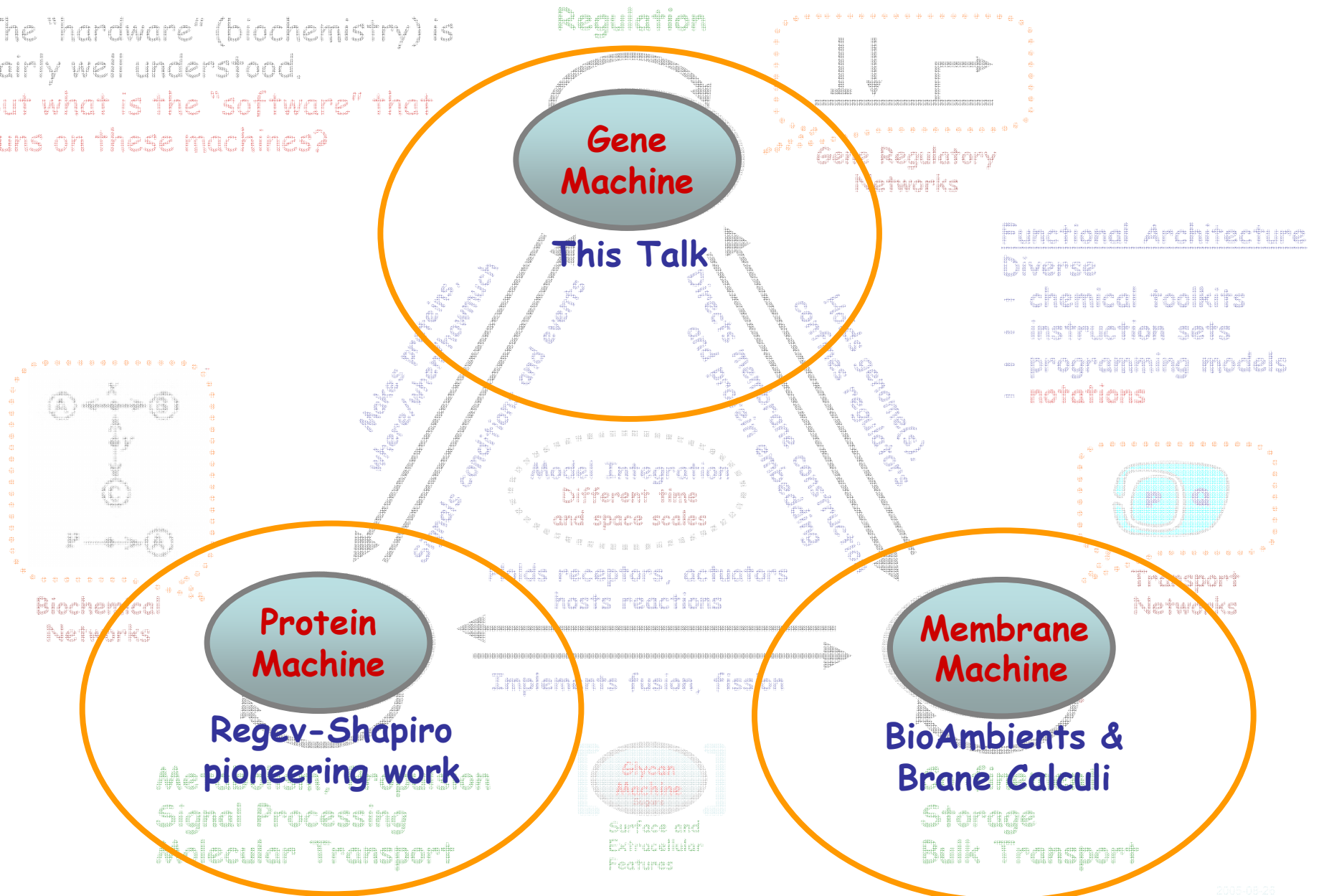

# Reactive Systems

- **Modeling biological systems**
  - Not as continuous systems (often highly nonlinear)
  - But as discrete **reactive systems**; abstract machines with:
    - **States** represent situations
    - Event-driven **transitions** between states represent dynamics
  - The adequacy of describing (discrete) complex systems as reactive systems has been argued convincingly [Harel]
- **Many biological systems exhibit features of reactive systems:**
  - Deep layering of abstractions
  - Complex composition of simple components
  - Discrete transitions between states
  - Digital coding and processing of information
  - Reactive information-driven behavior
  - High degree of concurrency and nondeterminism
  - "Emergent behavior" not obvious from part list



# Stochastic $\pi$ -calculus Executive Summary

- A simple variant of  $\pi$ -calculus:
  - Channels have stochastic "firing" rates with exponential distribution.
  - Nondeterministic choice becomes *stochastic race*.
  - Cuts down to CTMCs (Continuous Time Markov Chains) in the finite case (not always). Then, standard analytical tools are applicable.
  - Can be given friendly automata-like scalable graphical syntax (work with Andrew Phillips).
  - Is directly executable (via the Gillespie algorithm from physical chemistry).
  - Is analyzable (large body of literature, at least in the non-stochastic case).

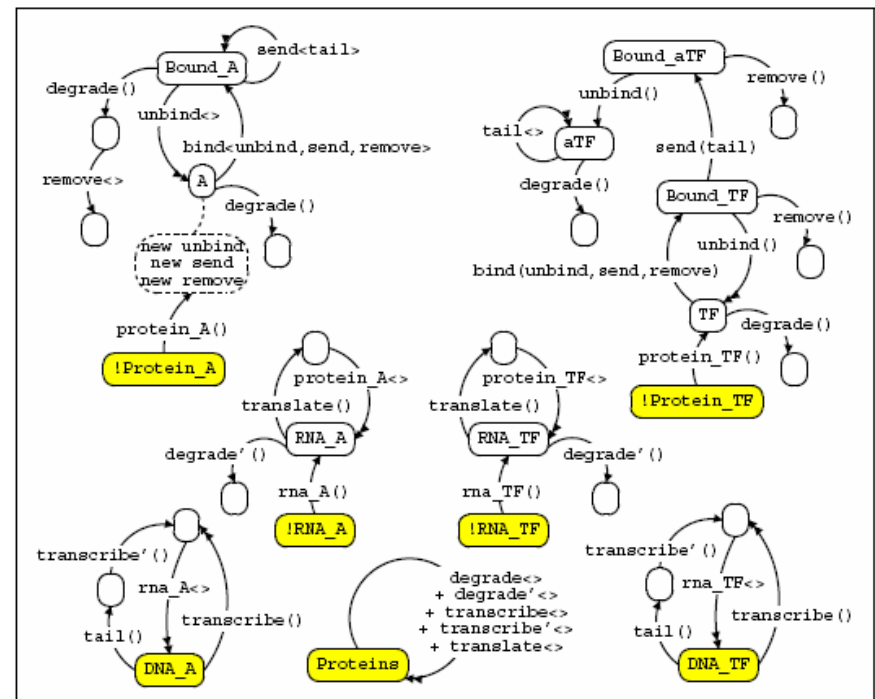

Figure 2. Regulating Gene Expression by Positive Feedback [9]

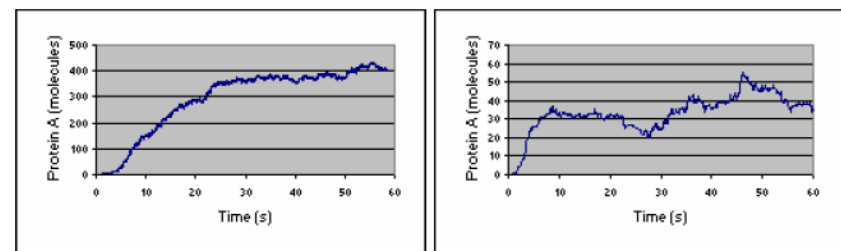

Figure 3. Protein A molecules v.s. time in presence (left) and absence (right) of TF

A. Phillips, L. Cardelli. BioConcur'04.

# Importance of Stochastic Effects

- A **deterministic** system:
  - May get "stuck in a fixpoint".
  - And hence **never oscillate**.
- A similar **stochastic** system:
  - May be "thrown off the fixpoint" by stochastic noise, entering a long orbit that will later bring it back to the fixpoint.
  - And hence **oscillate**.

## Mechanisms of noise-resistance in genetic oscillators

Jose´ M. G. Vilar, Hao Yuan Kueh, Naama Barkai, Stanislas Leibler  
 PNAS April 30, 2002 vol. 99 no. 9 p.5991

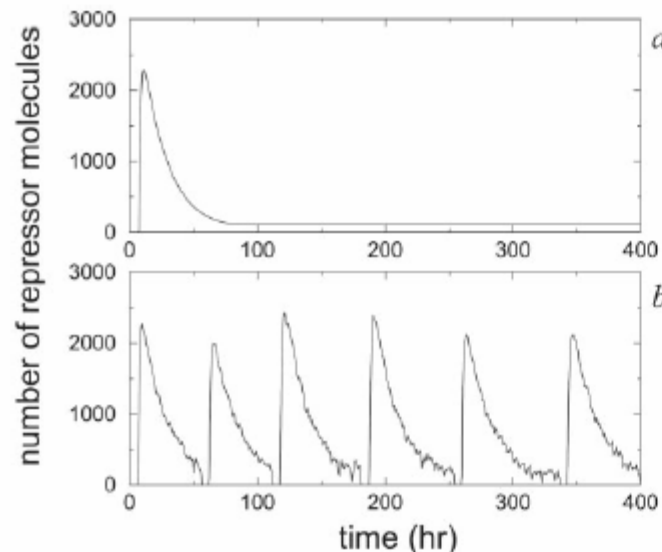

Fig. 5. Time evolution of  $R$  for the deterministic Eq. [1] (a) and stochastic (b) versions of the model. The values of the parameters are as in the caption of Fig. 1, except that now we set  $\delta_R = 0.05 \text{ h}^{-1}$ . For these parameter values,  $\tau < 0$ , so that the fixed point is stable.

Surprisingly enough, we have found that parameter values that give rise to a stable steady state in the deterministic limit continue to produce reliable oscillations in the stochastic case, as shown in Fig. 5. Therefore, the presence of noise not only changes the behavior of the system by adding more disorder but can also lead to marked qualitative differences.

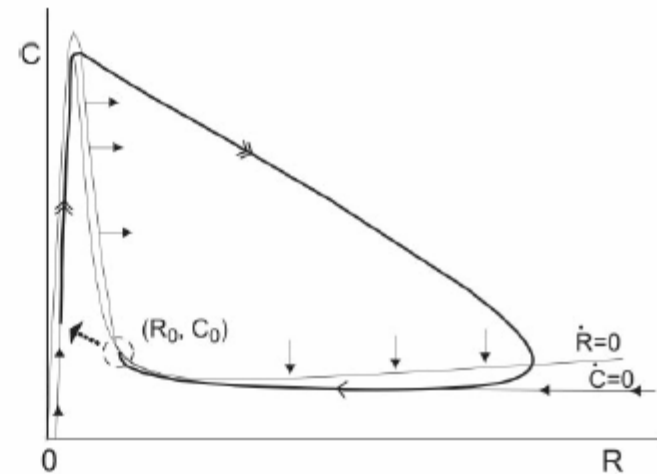
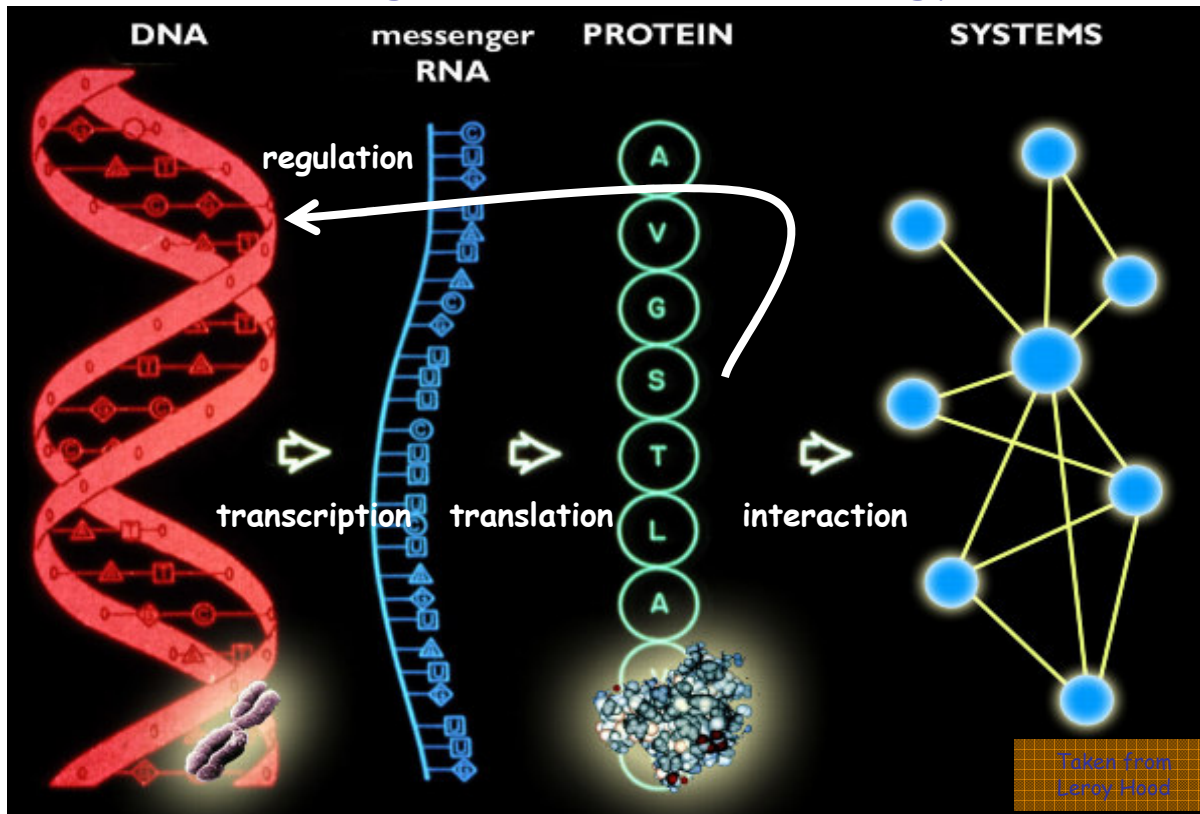

Fig. 6. Phase portrait as in Fig. 4 but for a situation in which the system falls into the stable fixed point  $(R_0, C_0)$ . The dotted arrow to the left of the fixed point illustrates a perturbation that would initiate a single sweep of the (former) oscillatory trajectory.

# Gene Networks

# The Gene Machine

## The "Central Dogma" of Molecular Biology



4-letter digital code

4-letter digital code

20-letter digital code

50.000(?) shapes

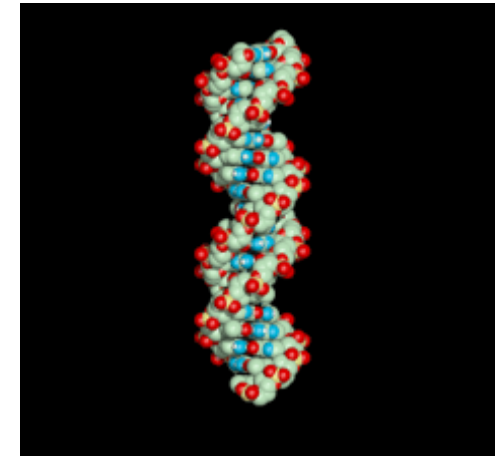

[DNA Tutorial](#)

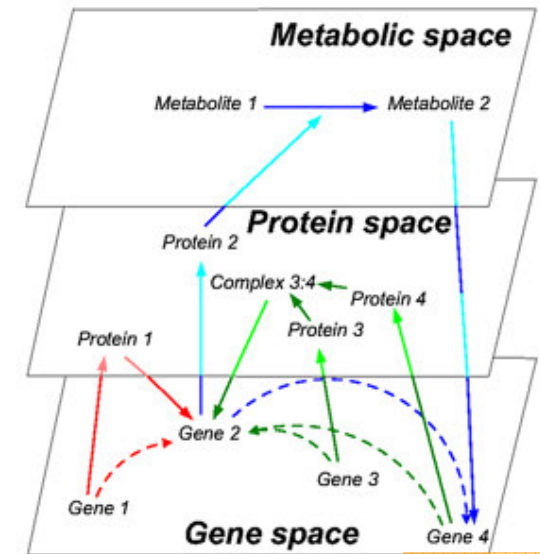

Taken from Pedro Mendes

2005-08-26

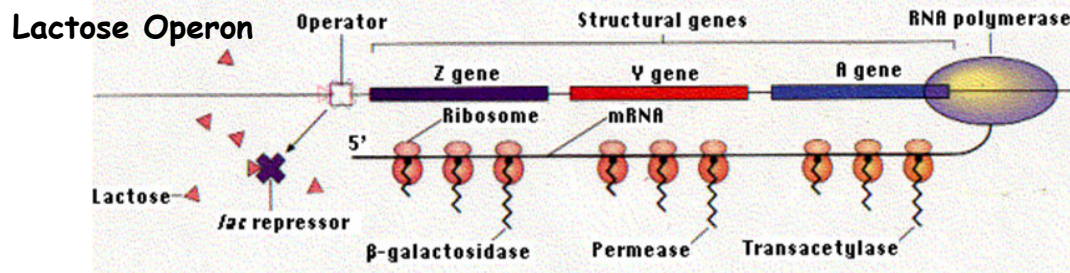

# The Gene Machine "Instruction Set"

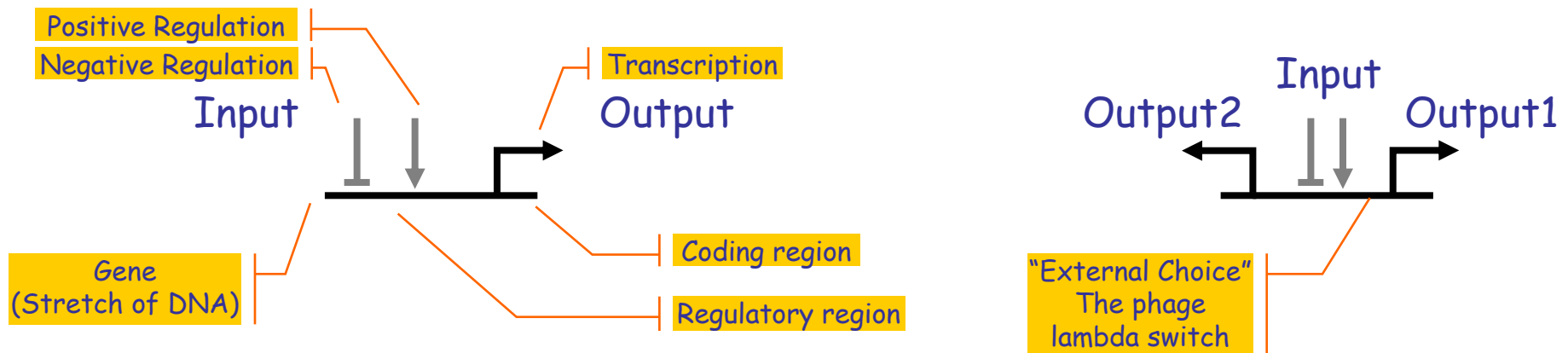

Regulation of a gene (positive and negative) influences transcription. The regulatory region has precise DNA sequences, but not meant for coding proteins: meant for binding regulators.

Transcription produces molecules (RNA or, through RNA, proteins) that bind to regulatory region of other genes (or that are end-products).

## Human (and mammalian) Genome Size

3Gbp (Giga base pairs) 750MB @ 4bp/Byte (CD)

Non-repetitive: 1Gbp 250MB

In genes: 320Mbp 80MB

Coding: 160Mbp 40MB

Protein-coding genes: 30,000-40,000

## M.Genitalium (smallest true organism)

580,073bp 145KB (eBook)

E.Coli (bacteria): 4Mbp 1MB (floppy)

Yeast (eukarya): 12Mbp 3MB (MP3 song)

Wheat 17Gbp 4.25GB (DVD)



# Gene Composition

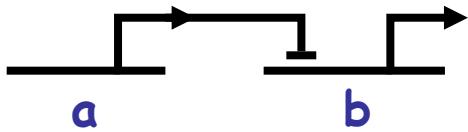

Is a shorthand for:

Under the assumptions [Kim & Tidor]

- 1) The solution is well-stirred  
(no spatial dependence on concentrations or rates).
- 2) There is no regulation cross-talk.
- 3) Control of expression is at transcription level only  
(no RNA-RNA or RNA-protein effects)
- 4) Transcriptions and translation rates monotonically affect mRNA and protein concentrations resp.

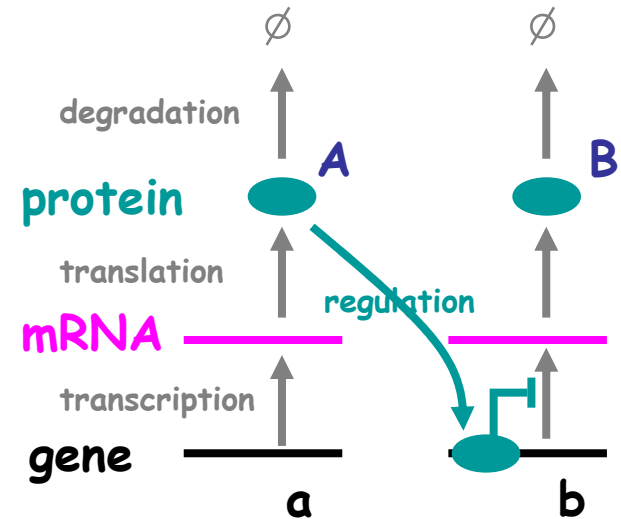

Ex: Bistable Switch



Ex: Oscillator

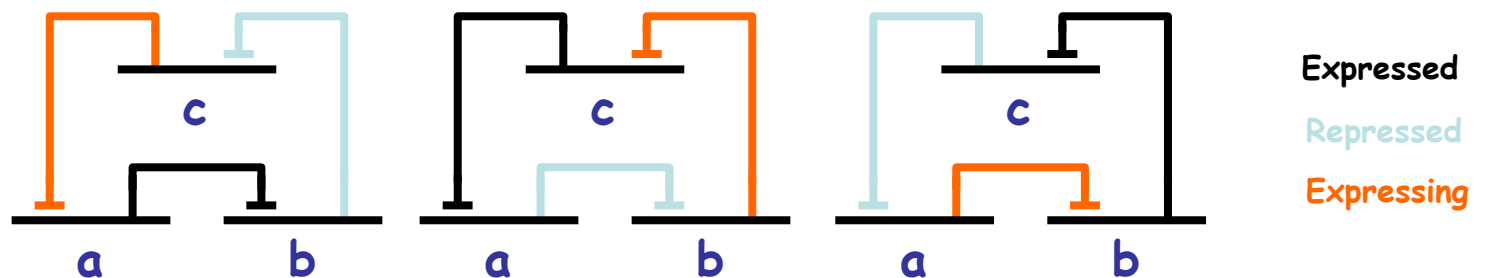

# Gene Regulatory Networks

<http://strc.herts.ac.uk/bio/maria/NetBuilder/>

NetBuilder

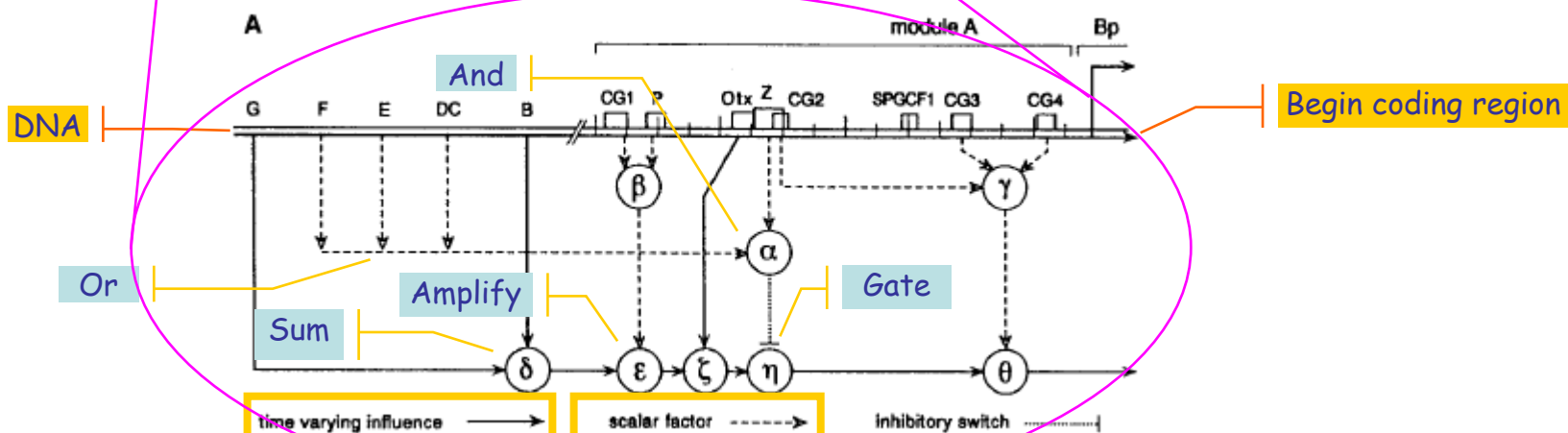
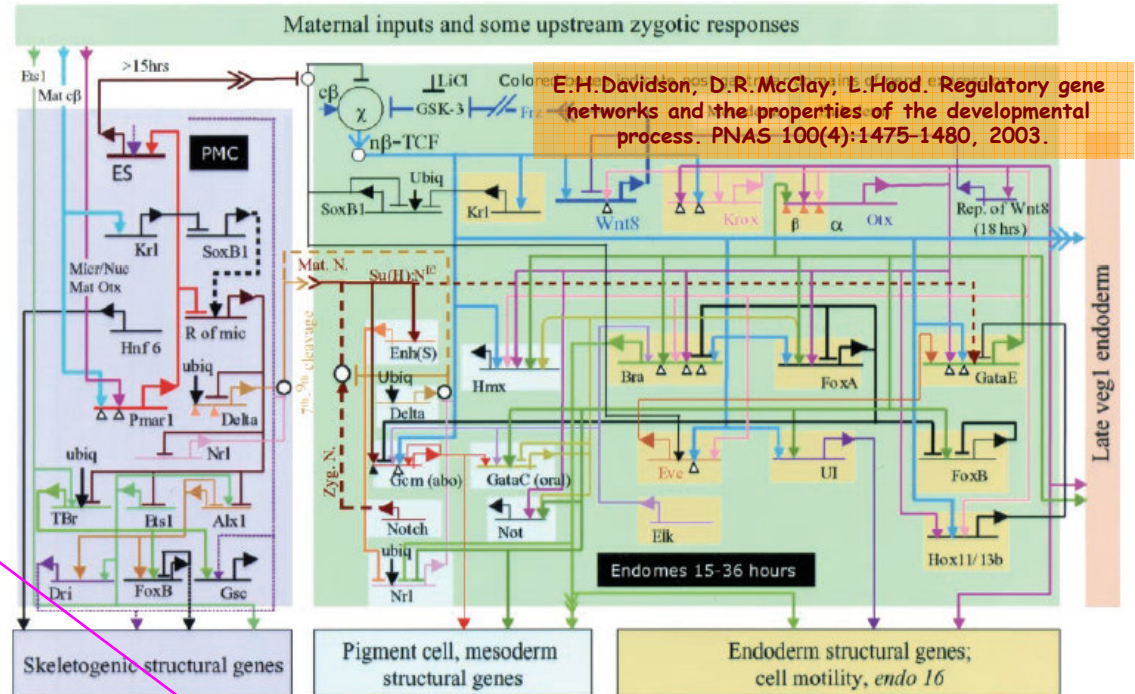

C-H. Yuh, H. Bolouri, E.H. Davidson. Genomic Cis-Regulatory Logic: Experimental and Computational Analysis of a Sea Urchin Gene. Science 279:1896-1902, 1998

# (The Classical ODE Approach)

[Chen, He, Church]

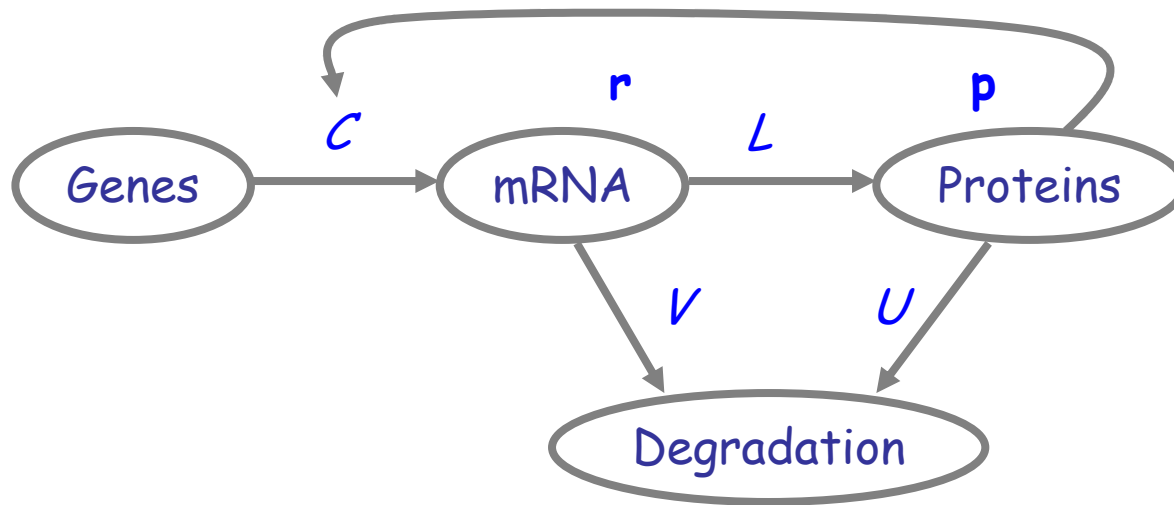

I.e.: to model an operating system, write a set of differential equations relating the concentrations in memory of data structures and stack frames over time. (Duh!)

$$\frac{d\mathbf{r}}{dt} = f(\mathbf{p}) - V\mathbf{r}$$

$$\frac{d\mathbf{p}}{dt} = L\mathbf{r} - U\mathbf{p}$$

$n$ : number of genes

$\mathbf{r}$  mRNA concentrations (n-dim vector)

$\mathbf{p}$  protein concentrations (n-dim vector)

$f(\mathbf{p})$  transcription functions:  
(n-dim vector polynomials on  $\mathbf{p}$ )

# Nullary Gate

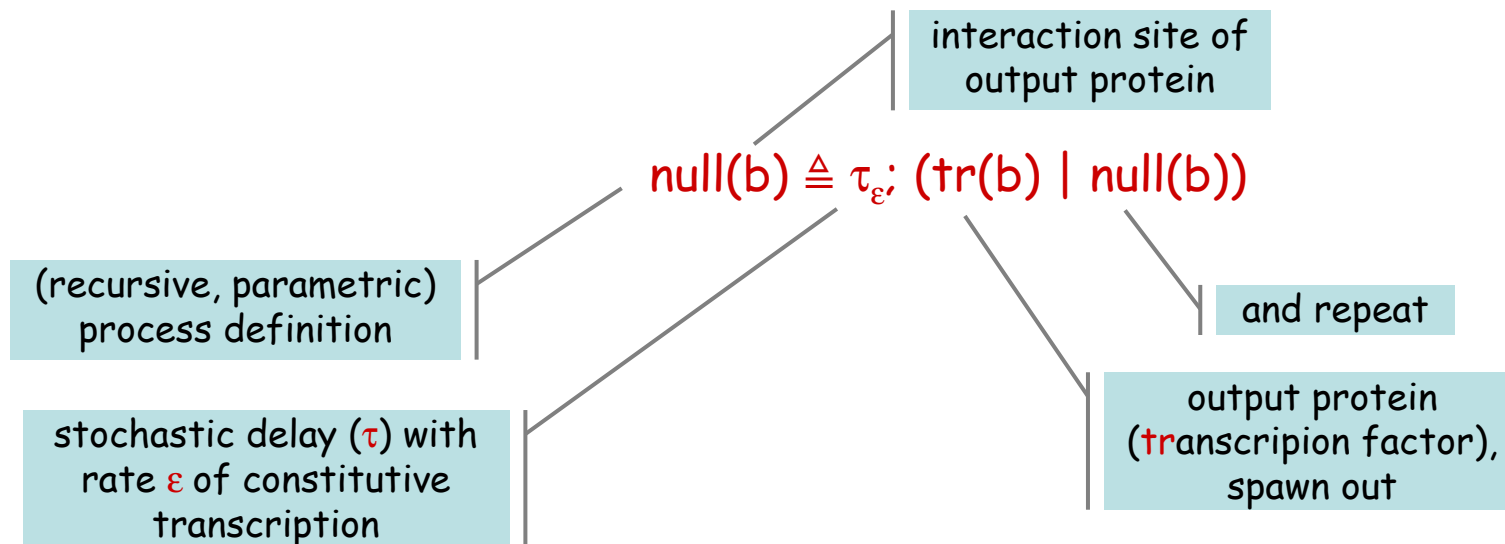
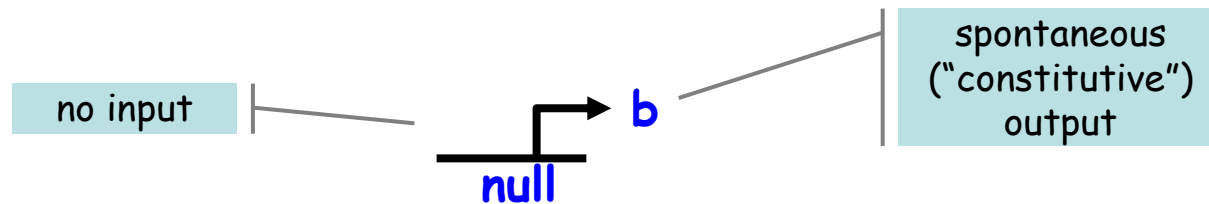

A stochastic rate  $r$  is always associated with each channel  $a_r$  (at channel creation time) and delay  $\tau_r$ , but is often omitted when unambiguous.

# Production and Degradation

Degradation is extremely important and often deliberate; it changes unbounded growth into (roughly) stable signals.

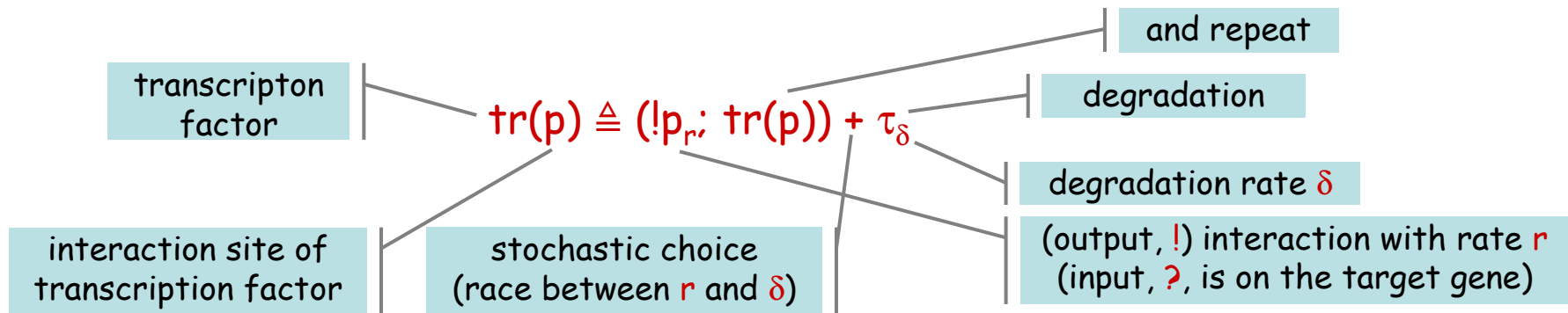

A transcription factor is a *process* (not a message or a channel): it has behavior such as interaction on  $p$  and degradation.

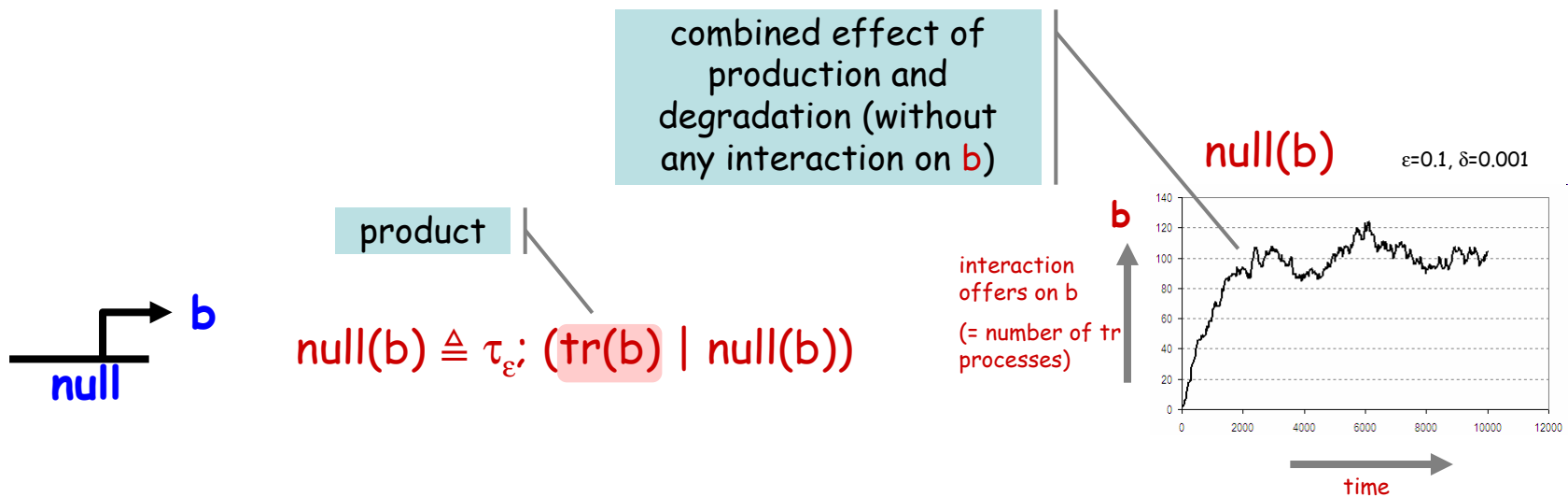



# Unary Pos Gate

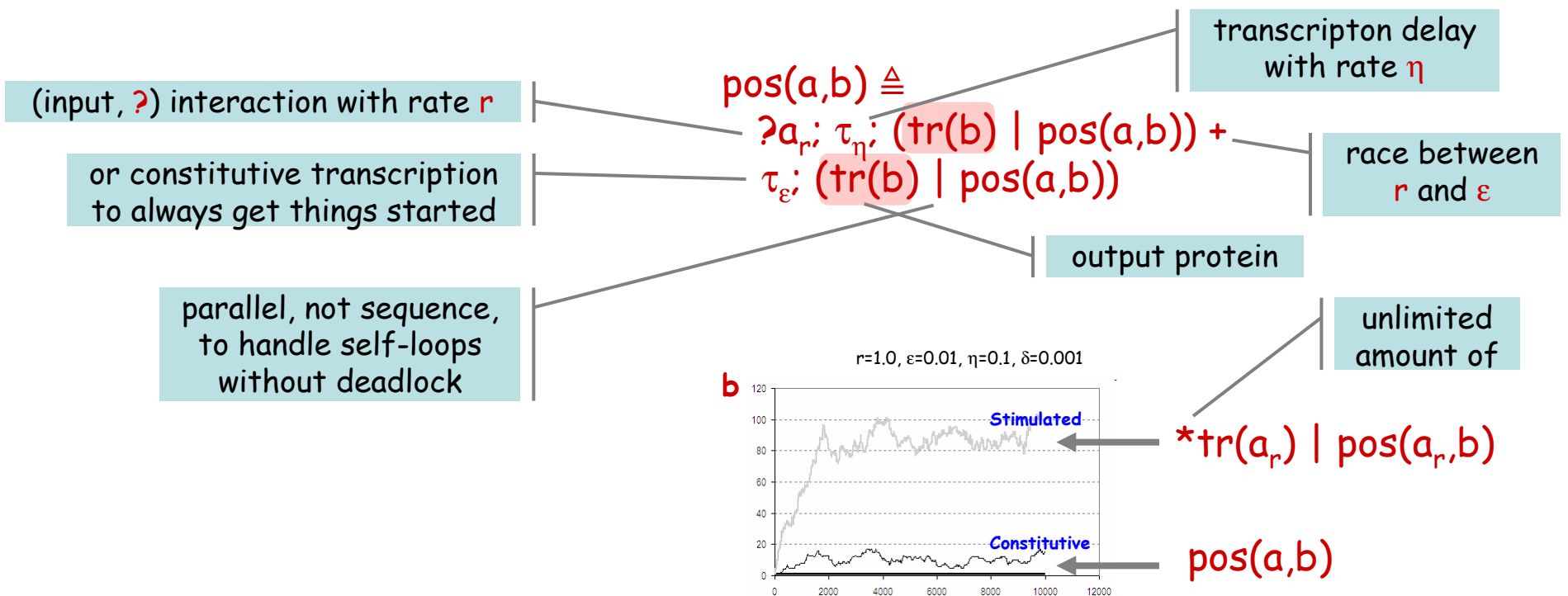
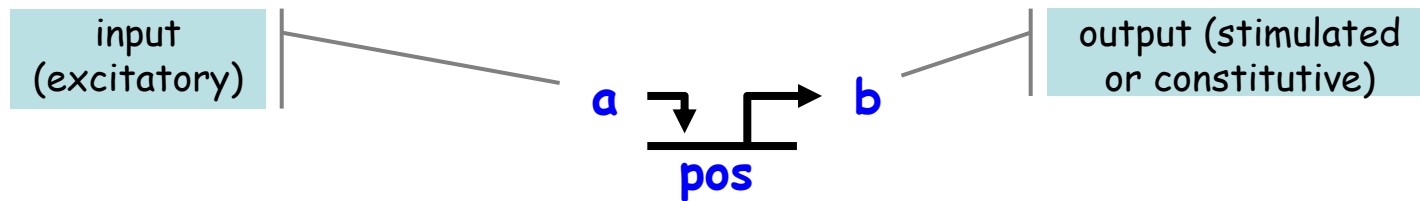

# Unary Neg Gate

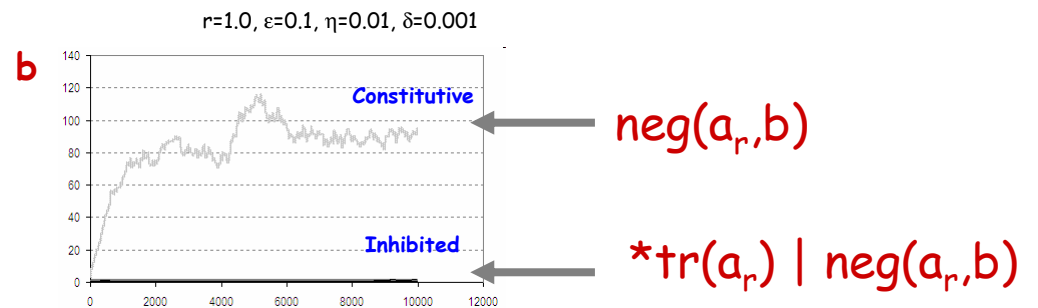
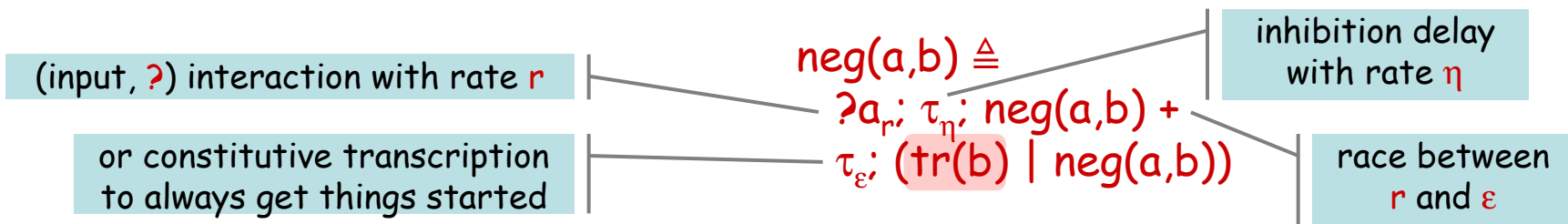
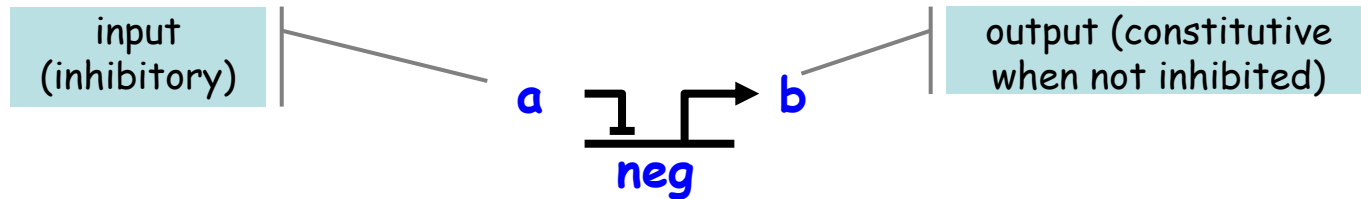

# Signal Amplification

pos(a,b) |  
pos(b,c)

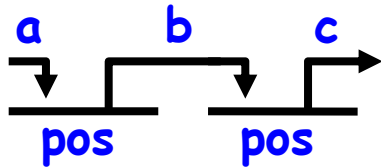

$$\text{pos}(a,b) \triangleq \tau_{a_r}; \tau_{\eta}; (\text{tr}(b) | \text{pos}(a,b)) + \tau_{\varepsilon}; (\text{tr}(b) | \text{pos}(a,b))$$

$$\text{tr}(p) \triangleq (!p_r; \text{tr}(p)) + \tau_{\delta}$$

E.g. 1 a that interacts twice before decay can produce 2 b that each interact twice before decay, which produce 4 c...

With little degradation

$r=1.0, \varepsilon=0.01, \eta=0.1, \delta=0.00001$

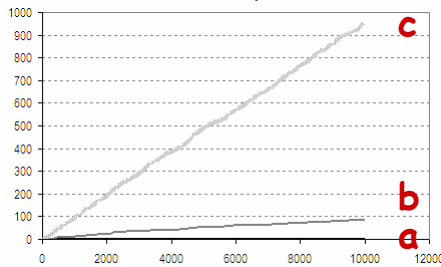

pos(a,b) | pos(b,c)

$r=1.0, \varepsilon=0.01, \eta=0.1, \delta=0.001$

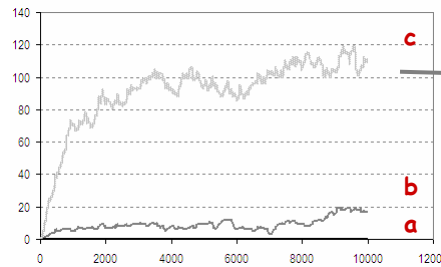

pos(a,b) | pos(b,c)

even with no a input, constitutive production of b gets amplified to a high c signal

# Signal Normalization

neg(a,b) |  
neg(b,c)

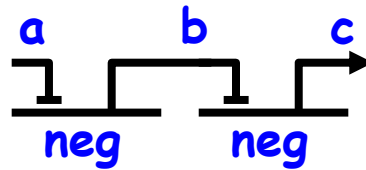

$$\text{neg}(a,b) \triangleq$$

$$\begin{aligned} & \text{?} a_{r'}; \tau_{\eta}; \text{neg}(a,b) + \\ & \tau_{\epsilon}; (\text{tr}(b) \mid \text{neg}(a,b)) \end{aligned}$$

$$\text{tr}(p) \triangleq (!p_{r'}; \text{tr}(p)) + \tau_{\delta}$$

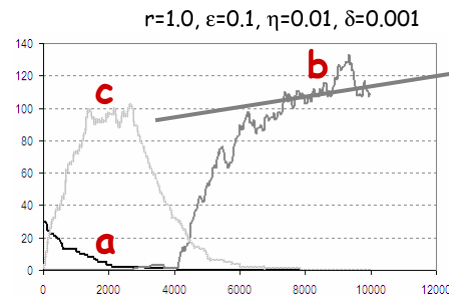

a non-zero input level, **a**,  
whether weak or strong,  
is renormalized to a  
standard level, **c**.

30\*tr(a) | neg(a,b) | neg(b,c)

# Self Feedback Circuits

pos(a,a)

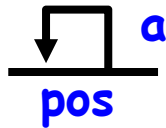

$\text{pos}(a,b) \triangleq$

$$\begin{aligned} & \gamma_{a_r}; (\text{tr}(b) \mid \text{pos}(a,b)) + \\ & \tau_{\epsilon}; (\text{tr}(b) \mid \text{pos}(a,b)) \end{aligned}$$

$\text{tr}(p) \triangleq (!p_r; \text{tr}(p)) + \tau_{\delta}$

(Can overwhelm degradation, depending on parameters)

$r=1.0, \epsilon=0.1, \delta=0.01$

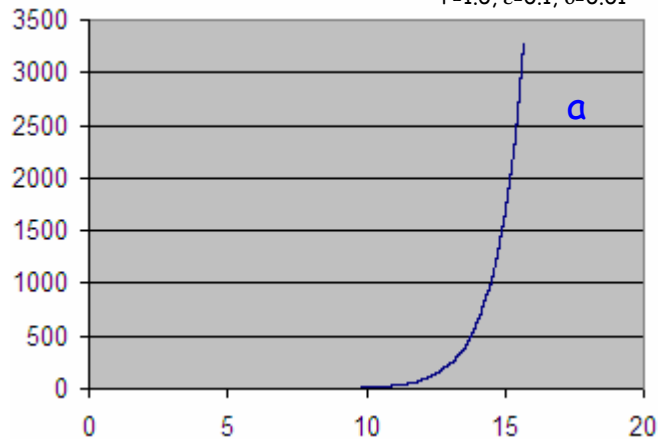

pos(a,a)

neg(a,a)

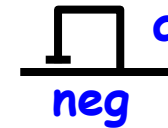

$\text{neg}(a,b) \triangleq$

$$\begin{aligned} & \gamma_{a_r}; \tau_{\eta}; \text{neg}(a,b) + \\ & \tau_{\epsilon}; (\text{tr}(b) \mid \text{neg}(a,b)) \end{aligned}$$

$\text{tr}(p) \triangleq (!p_r; \text{tr}(p)) + \tau_{\delta}$

high, to raise the signal

$r=1.0, \epsilon=10.0, h=1.0, \delta=0.005$

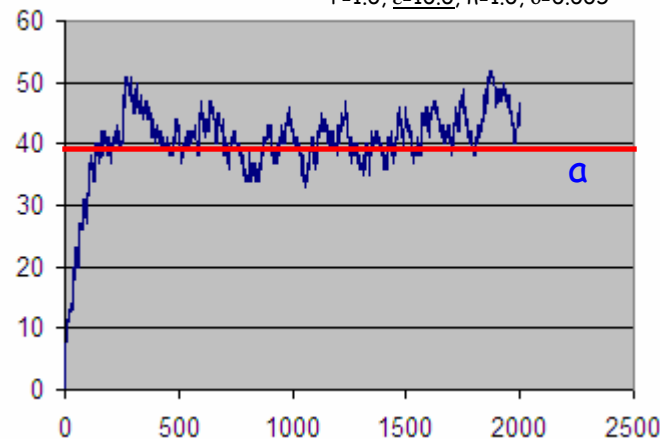

neg(a,a)

Less degradation  $\delta=0.0005$

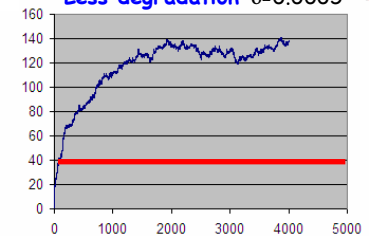

And a bit less  $\delta=0.0001$

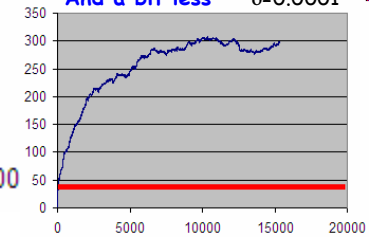



# Two-gate Feedback Circuits

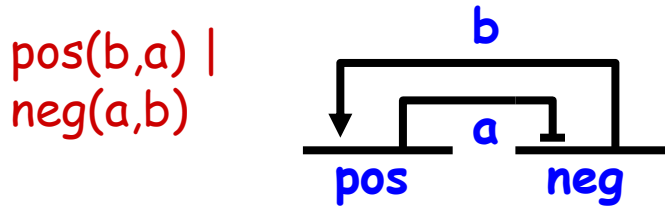

Monostable:

For some degradation rates is quite stable:

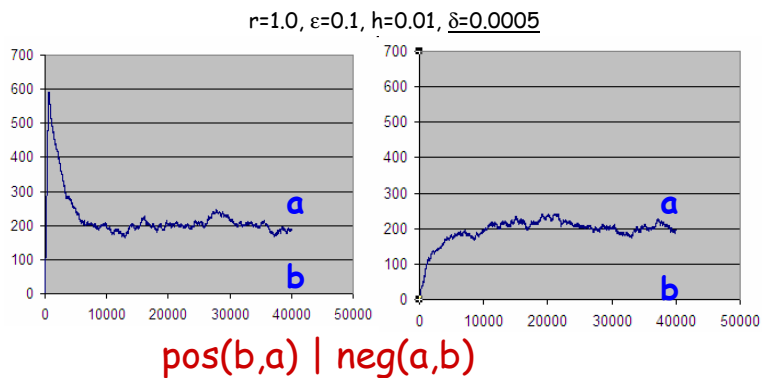

But with a small change in degradation, it goes wild:

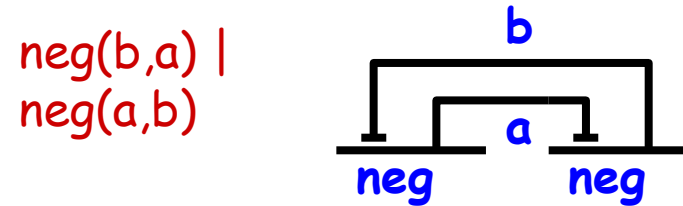
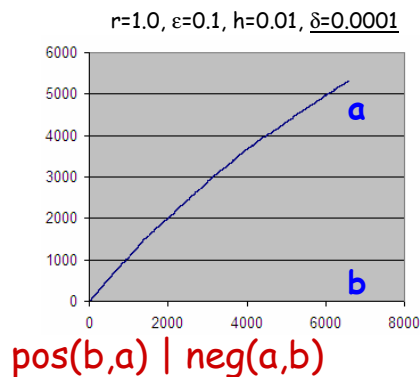

Bistable:

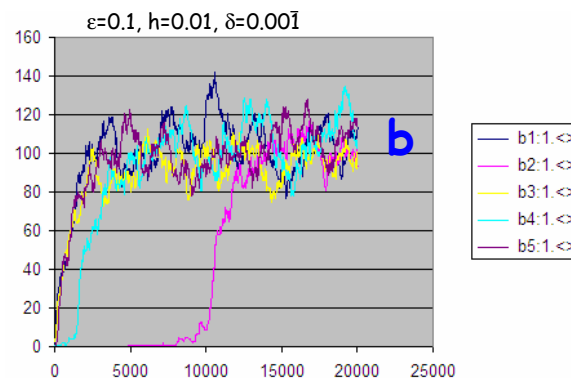
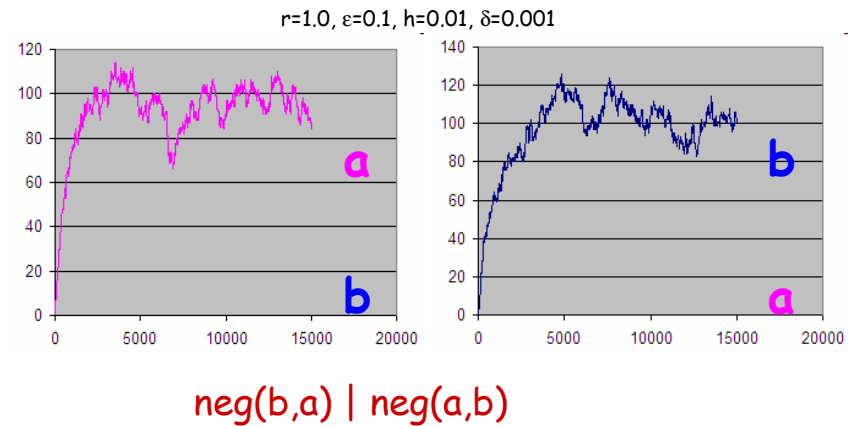

5 runs with  $r(a)=0.1$ ,  
 $r(b)=1.0$  shows that  
circuit is now biased  
towards expressing  $b$

# Repressilator

$neg(a,b) \mid$   
 $neg(b,c) \mid$   
 $neg(c,a)$

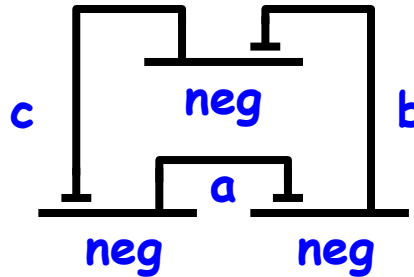

$neg(a,b) \triangleq$   
 $\tau_a r_i; \tau_b; neg(a,b) +$   
 $\tau_c; (tr(b) \mid neg(a,b))$

Same circuit, three different degradation models by chaining the tr component:

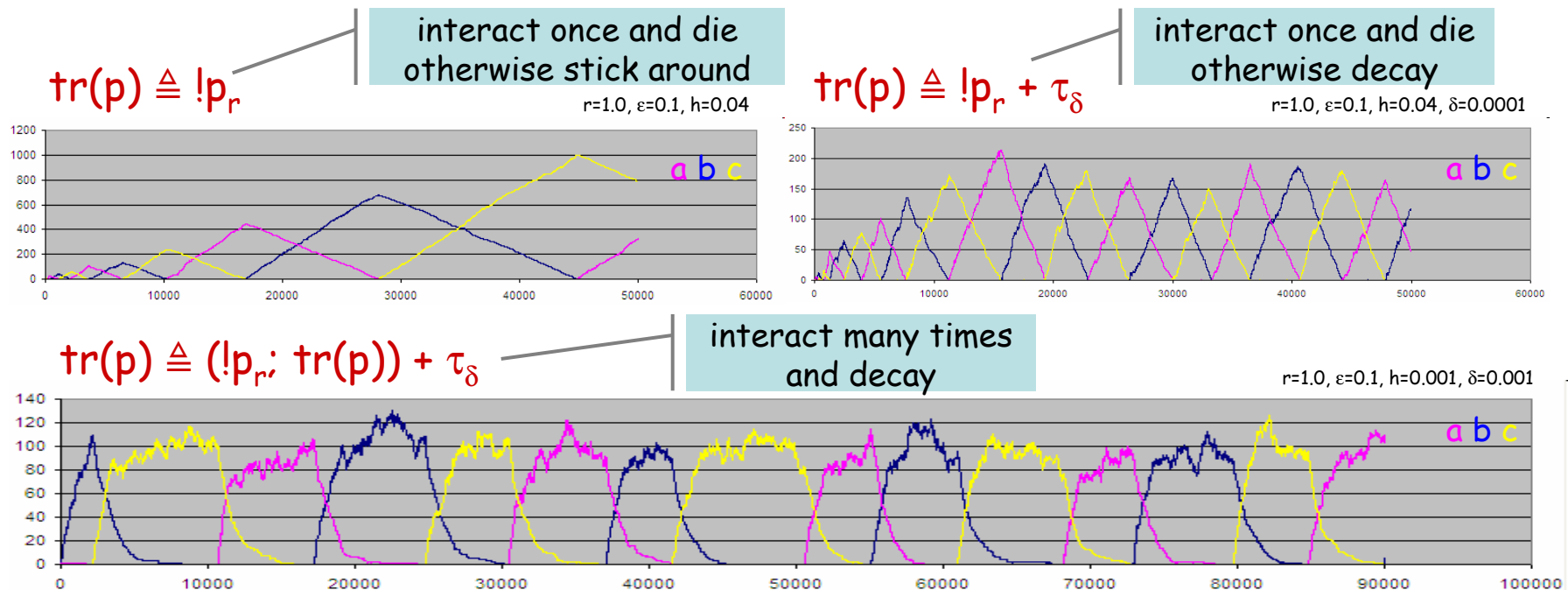

Subtle... at any point one gate is inhibited and the other two can fire constitutively. If one of them fires first, nothing really changes, but if the other one fires first, then the cycle progresses.

# System Properties: Oscillation Parameters

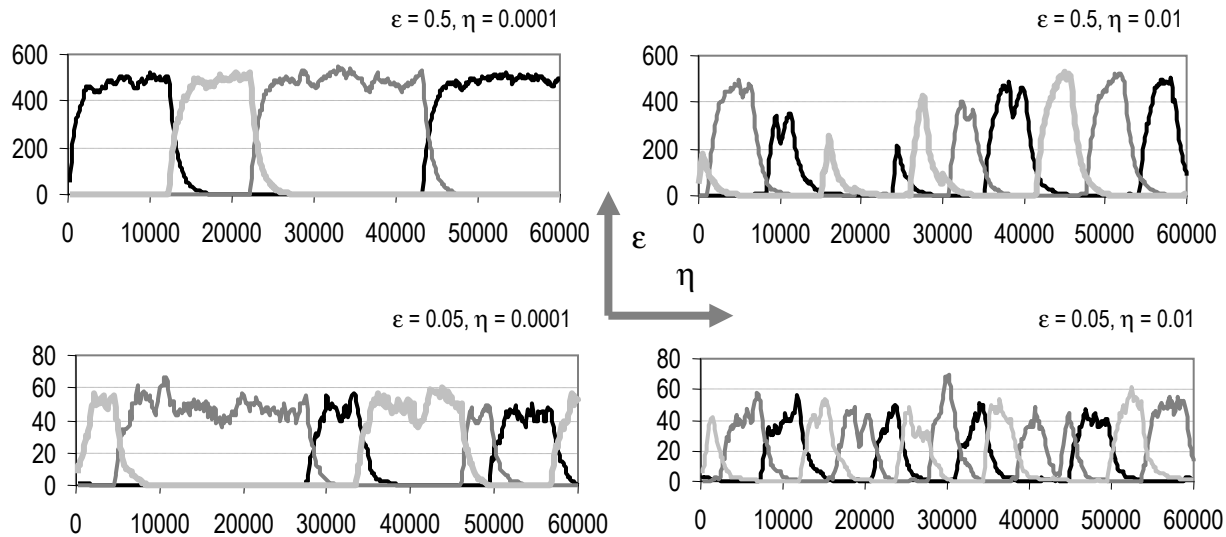

The constitutive rate  $\epsilon$  (together with the degradation rate) determines oscillation amplitude, while the inhibition rate  $\eta$  determines oscillation frequency.

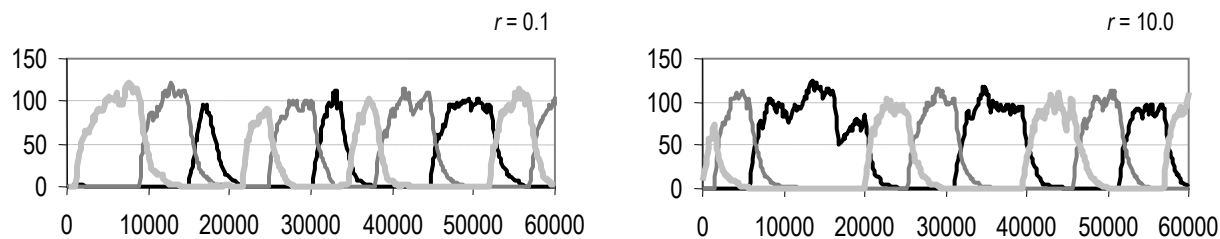

We can view the interaction rate  $r$  as a measure of the volume (or temperature) of the solution; that is, of how often transcription factors bump into gates. Oscillation frequency and amplitude remain unaffected in a large range of variation of  $r$ .

# Repressilator in SPiM

```
val dk = 0.001      (* Decay rate *)
val eta = 0.001    (* Inhibition rate *)
val cst = 0.1      (* Constitutive rate *)

let tr(p:chan()) =
  do !p; tr(p)
  or delay@dk

let neg(a:chan(), b:chan()) =
  do ?a; delay@eta; neg(a,b)
  or delay@cst; (tr(b) | neg(a,b))

(* The circuit *)
val bnd = 1.0      (* Protein binding rate *)
new a@bnd: chan()
new b@bnd: chan()
new c@bnd: chan()

run (neg(c,a) | neg(a,b) | neg(b,c))
```

# System Properties: Fixpoints

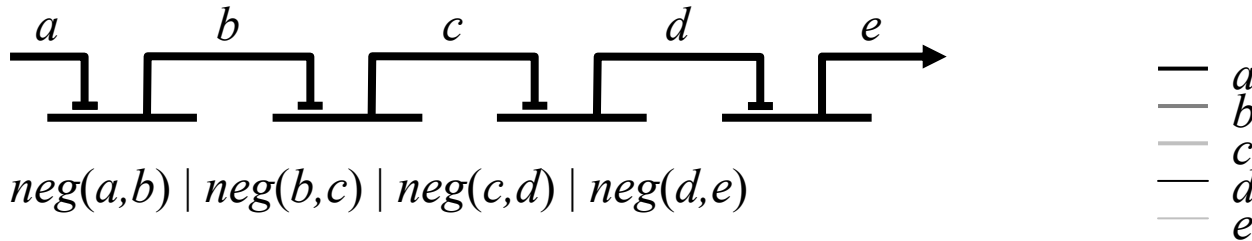

A sequence of neg gates behaves as expected, with alternating signals, (less "Booleanly" depending on attenuation).

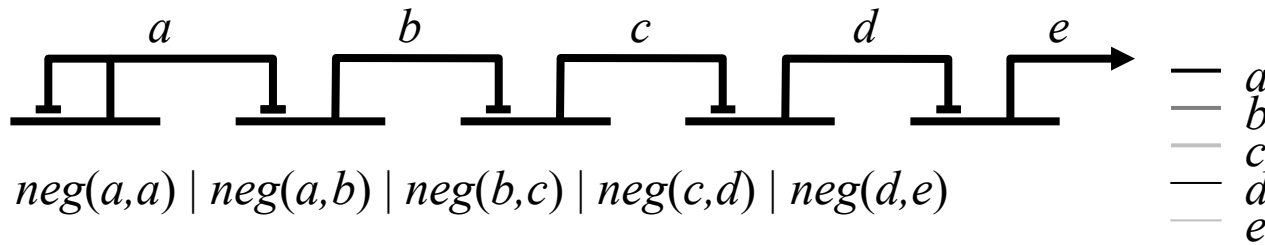
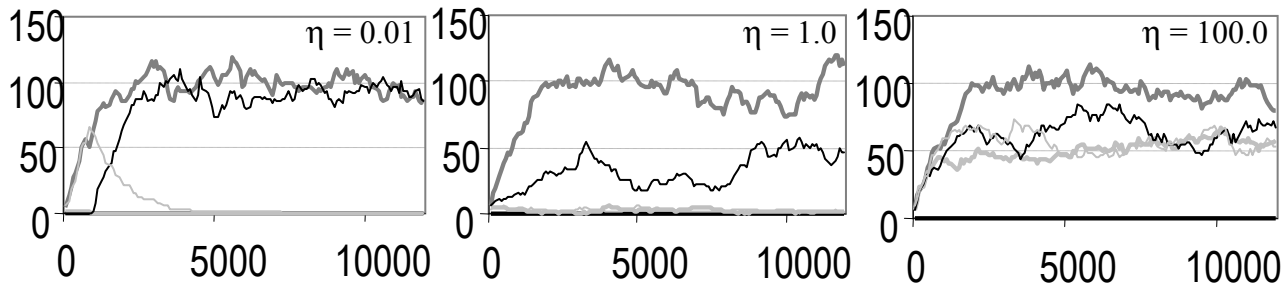

Now add a self-loop at the head. **Not a Boolean circuit!**

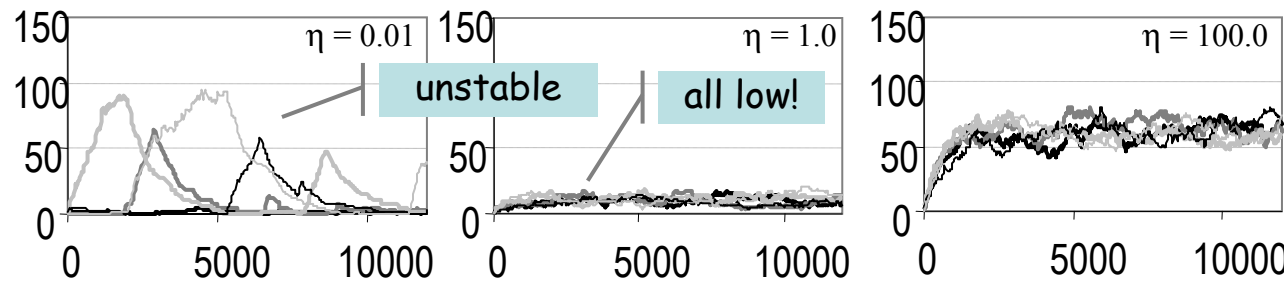

No more alternations, because... each gate is at its fixpoint.

# Guet et al.

Combinatorial Synthesis of Genetic Networks, Guet, Elowitz, Hsing, Leibler, 1996, *Science*, May 2002, 1466-1470.

They engineered in E.Coli all genetic circuits with four single-input gates; such as this one:

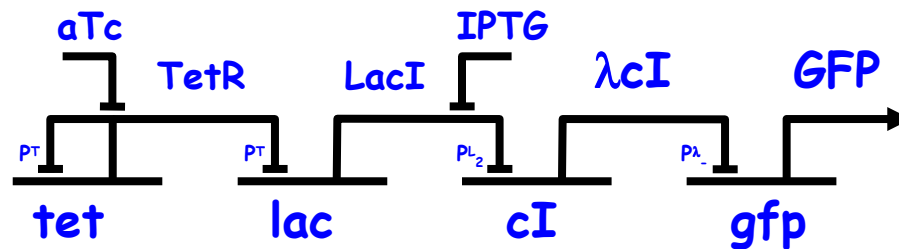

Then they measured the *GFP* output (a fluorescent protein) in presence or absence of each of two inhibitors (*aTc* and *IPTG*).

## Experiment:

<i>aTc</i>	0101
<i>IPTG</i>	0011
<i>GFP</i>	0100

The output of some circuits did not seem to make any sense...

Here "1" means "high brightness" and "0" means "low brightness" on a population of bacteria after some time. (I.e. integrated in space and time.)

# Further Building Blocks

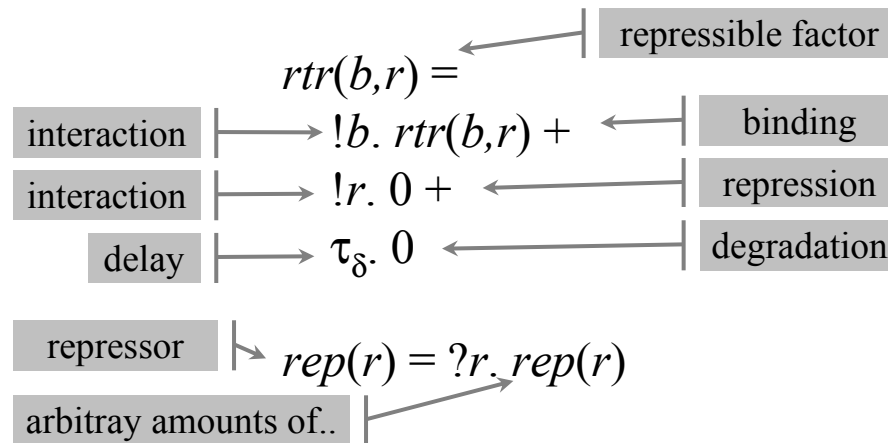
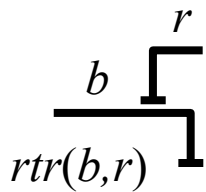
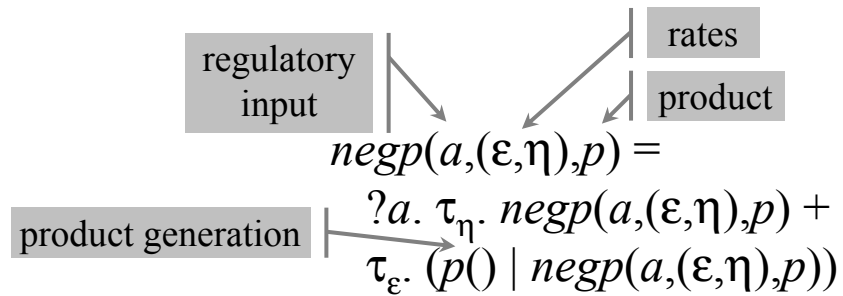
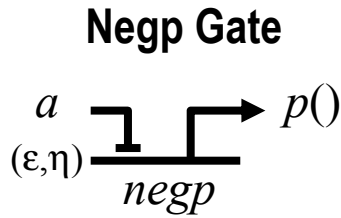



# D038/lac<sup>-</sup>

D038/lac<sup>-</sup>

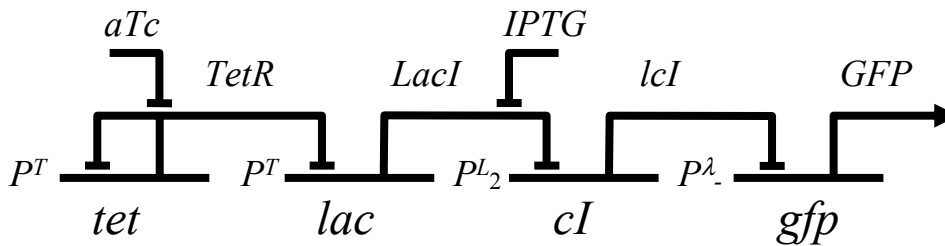

Experiment:

<i>aTc</i>	0101
<i>IPTG</i>	0011
<i>GFP</i>	0100

*channels*  $TetR:r_1, LacI:r_2, cI:r_3, GFP:r_4, aTc:r_5, IPTG:r_6$

$P^T = (\epsilon_1, \eta_1) \quad P^{L_2} = (\epsilon_2, \eta_2) \quad P^{\lambda_-} = (\epsilon_3, \eta_3)$

$tet = negp(TetR, P^T, rtr(TetR, aTc))$

$lac = negp(TetR, P^T, rtr(LacI, IPTG))$

$cI = negp(LacI, P^{L_2}, tr(cI))$

$gfp = negp(cI, P^{\lambda_-}, tr(GFP))$

$D038lac^- = tet | lac | cI | gfp \quad | \quad rep(aTc) | rep(IPTG)$

molecules

promoters

genes

repressors  
(when present)

Naïve “Boolean” analysis would suggest GFP=0.5 (oscillation) because of self-loop.

GFP=0 there is consistent only with (somehow) the head loop setting TetR=LacI=0. But in that case, aTc should have no effect (it can only subtract from those signals) but instead it sets GFP=1.

Hence we need to understand better the “dynamics” of this network.

# Simulation results for D038/lac<sup>-</sup>

Experiment:

*aTc* 0101

*IPTG* 0011

*GFP* 0100

$r=1.0, \epsilon=0.1, h=1.0, \delta=0.001$

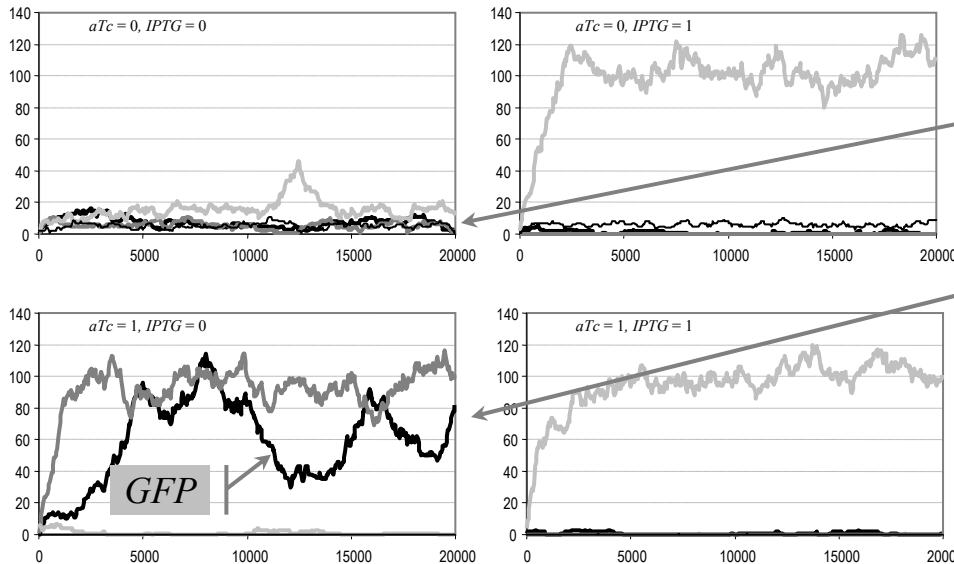

The fixpoint effect can explain this (all signals set very low).

Then, aTc can destabilize the fixpoint, explaining GFP high (oscillating)

$r = 1.0, \epsilon = 0.1, \eta = 0.25 (P^T), \eta = 1.0 (P^{L_2}, P^\lambda), \delta = 0.001$

D038/lac<sup>-</sup>

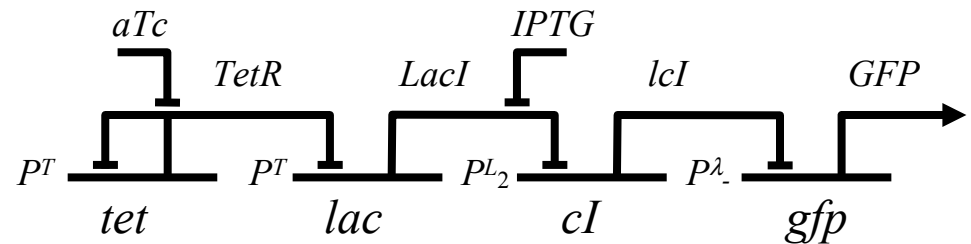

# D016/lac<sup>-</sup>

D016/lac<sup>-</sup>

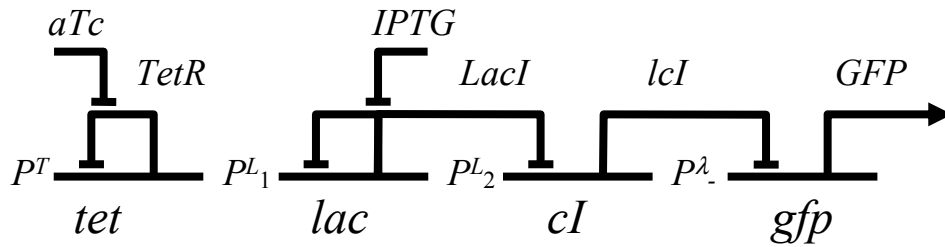

Experiment:

<i>aTc</i>	0101
<i>IPTG</i>	0011
<i>GFP</i>	1000

How can aTc affect the result??

One theory: aTc prevents the self-inhibition of tet, so that a very large quantity of TetR is produced. That then overloads the overall degradation machinery of the cell, affecting the rest of the circuit.

Even so, how can GFP be high here?

Even the fixpoint explanation fails here, unless we assume that the lac gate is operating in its instability region.

channels  $TetR:r_1, LacI:r_2, lacI:r_3, GFP:r_4, aTc:r_5, IPTG:r_6$

$P^T = [\epsilon_1, \eta_1] \quad P^{L_2} = [\epsilon_2, \eta_2] \quad P^{\lambda_-} = [\epsilon_3, \eta_3] \quad P^{L_1} = [\epsilon_4, \eta_4]$

$tet = negp[TetR, P^T, rtr[TetR, aTc]]$

$lac = negp[LacI, P^{L_1}, rtr[LacI, IPTG]]$

$cI = negp[LacI, P^{L_2}, tr[lacI]]$

$gfp = negp[lacI, P^{\lambda_-}, tr[GFP]]$

$D016lac^- = tet | lac | cI | gfp | rep[aTc] | rep[IPTG]$

promoters

genes

repressors

# Simulation results for D016/lac<sup>-</sup>

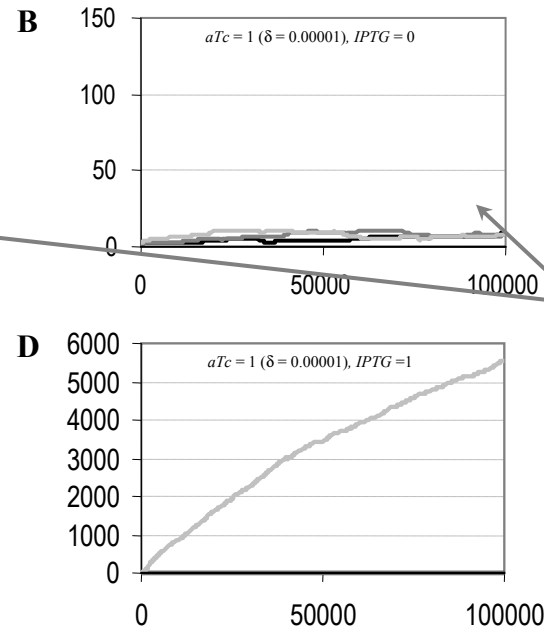
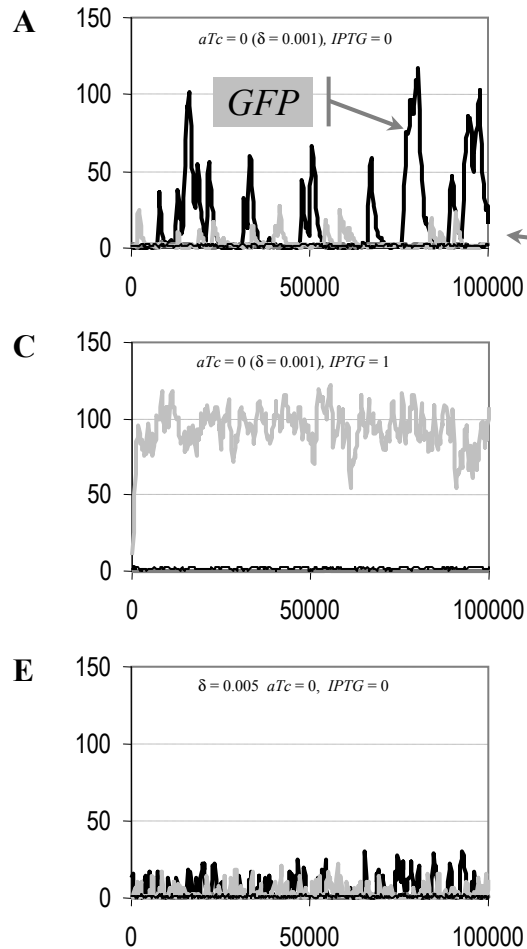

— *GFP*  $r = 1.0$   
 — *LacI*  $\epsilon = 0.1$   
 — *lcl*  $\eta = 0.01$   
 — *TetR*

**D016/lac<sup>-</sup>**

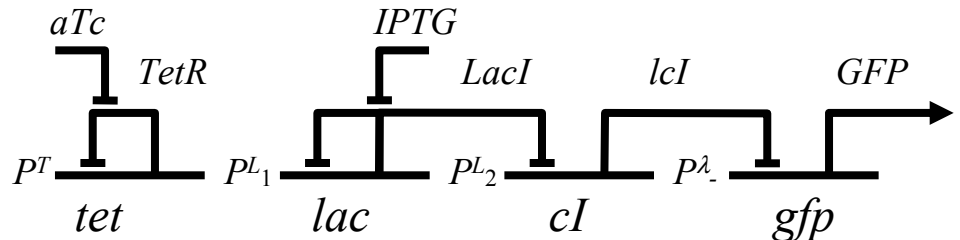

**Experiment:**

<i>aTc</i>	0101
<i>IPTG</i>	0011
<i>GFP</i>	1000

The fixpoint effect, in instability region, explains this: GFP high because wildly oscillating.

Overloading of degradation machinery, induced by aTc, can reinstate the fixpoint regime.

# What was the point?

- Deliberately pick a controversial/unsettled example to test the methodology.
- Show that we can easily “play with the model” and run simulations.
- Get a feeling for the kind of subtle effects that may play a role.
- Get a feeling for kind of analysis that is required to understand the behavior of these systems.
- In the end, we are never “understanding” anything; we are just building theories/models that support or contradict experiments (and that suggest further experiments).

# **Model Validation**

# Model Validation: Simulation

- **Basic stochastic algorithm: Gillespie**
  - Exact (i.e. based on physics) stochastic simulation of chemical kinetics.
  - Can compute concentrations and reaction times for biochemical networks.
- **Stochastic Process Calculi**
  - **BioSpi** [Shapiro, Regev, Priami, et. al.]
    - Stochastic process calculus based on Gillespie.
  - **BioAmbients** [Regev, Panina, Silverma, Cardelli, Shapiro]
    - Extension of BioSpi for membranes.
  - **Case study: Lymphocytes in Inflamed Blood Vessels** [Lecaa, Priami, Quaglia]
    - Original analysis of lymphocyte rolling in blood vessels of different diameters.
  - **Case study: Lambda Switch** [Celine Kuttler, IRI Lille]
    - Model of phage lambda genome (well-studied system).
  - **Case study: VICE** [U. Pisa]
    - Minimal prokaryote genome (180 genes) and metabolism of *whole* VIRTUAL CELL, in stochastic  $\pi$ -calculus, simulated under stable conditions for 40K transitions.
- **Hybrid approaches**
  - **Charon language** [UPenn]
    - Hybrid systems: continuous differential equations + discrete/stochastic mode switching.
  - Etc.



# Model Validation: "Program" Analysis

- **Causality Analysis**

- Biochemical pathways, ("concurrent traces" such as the one here), are found in biology publications, summarizing known facts.
- This one, however, was automatically generated from a program written in BioSpi by comparing traces of all possible interactions. [Curti, Priami, Degano, Baldari]
- One can play with the program to investigate various hypotheses about the pathways.

- **Control Flow Analysis**

- Flow analysis techniques applied to process calculi.
- Overapproximation of behavior used to answer questions about what "cannot happen".
- Analysis of positive feedback transcription regulation in BioAmbients [Flemming Nielson].

- **Probabilistic Abstract Interpretation**

- [DiPierro Wicklicky].

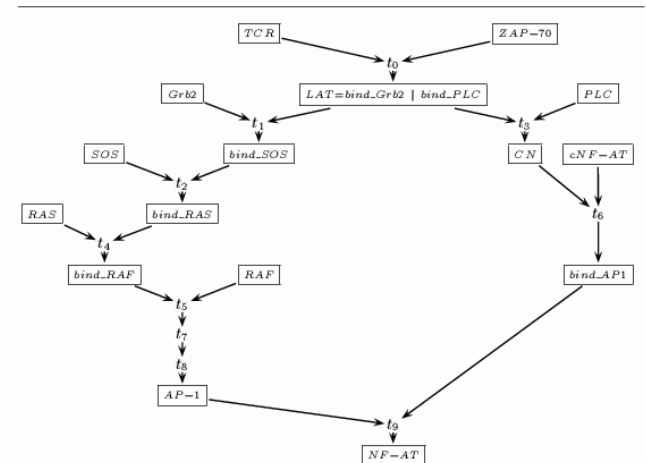

Fig.2. A computation of *Sys*. For readability, the processes, enclosed in boxes, have no address. Causality (both on transitions and processes) is represented by the (Hasse diagram resulting from the) arrows; their absence makes it explicit concurrent activities.

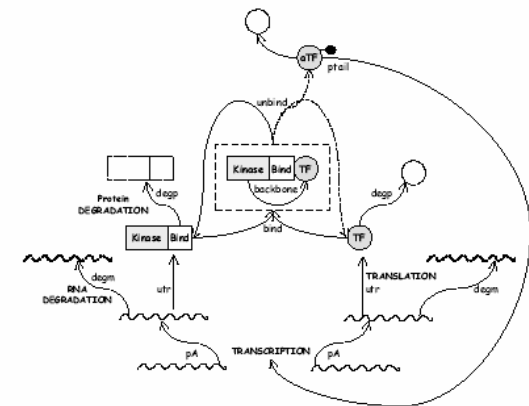

Fig. 1. Graphical presentation of Transcriptional Regulation by Positive Feedback [25].

# Model Validation: Modelchecking

- **Temporal**

- Software verification of biomolecular systems (NA pump)  
[Ciobanu]
- Analysis of mammalian cell cycle (after Kohn) in CTL.  
[Chabrier-Rivier Chiaverini Danos Fages Schachter]
  - E.g. is state  $S_1$  a necessary checkpoint for reaching state  $S_2$ ?

- **Quantitative: Simpathica/xssys**

[Antioniotti Park Policriti Ugel Mishra]

- Quantitative temporal logic queries of human Purine metabolism model.

Eventually(Always (PRPP = 1.7 \* PRPP1))  
implies  
steady\_state()  
and Eventually(Always(IMP < 2 \* IMP1))  
and Eventually(Always(hx\_pool < 10\*hx\_pool1))

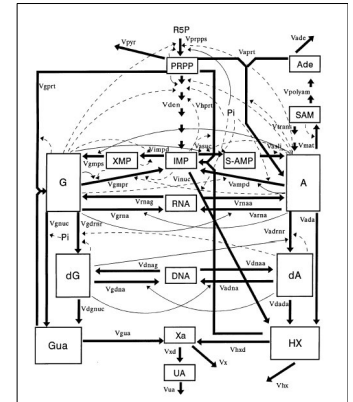

- **Stochastic: Spring**

[Parker Normal Kwiatkowska]

- Designed for stochastic (computer) network analysis
  - Discrete and Continuous Markov Processes.
  - Process input language.
  - Modelchecking of probabilistic queries.

# What Reactive Systems Do For Us

## We can write things down precisely

- We can modularly describe high structural and combinatorial complexity ("do programming").

## We can calculate and analyze

- Directly support simulation.
- Support analysis (e.g. control flow, causality, nondeterminism).
- Support state exploration (modelchecking).

## We can visualize

- Automata-like presentations.
- Petri-Net-like presentations.
- State Charts, Live Sequence Charts [Harel]
  - Hierarchical automata.
  - Scenario composition.

## We can reason

- Suitable equivalences on processes induce algebraic laws.
- We can relate different systems (e.g. equivalent behaviors).
- We can relate different abstraction levels.
- We can use equivalences for state minimization (symmetries).

## Disclaimers

- Some of these technologies are basically ready (medium-scale stochastic simulation and analysis, medium-scale nondeterministic and stochastic modelchecking).
- Others need to scale up significantly to be really useful. This is (has been) the challenge for computer scientists.

Many approaches, same basic philosophy, tools being built:

⇒ *Proc. Computational Methods in Systems Biology* [2003-2005]

# Conclusions

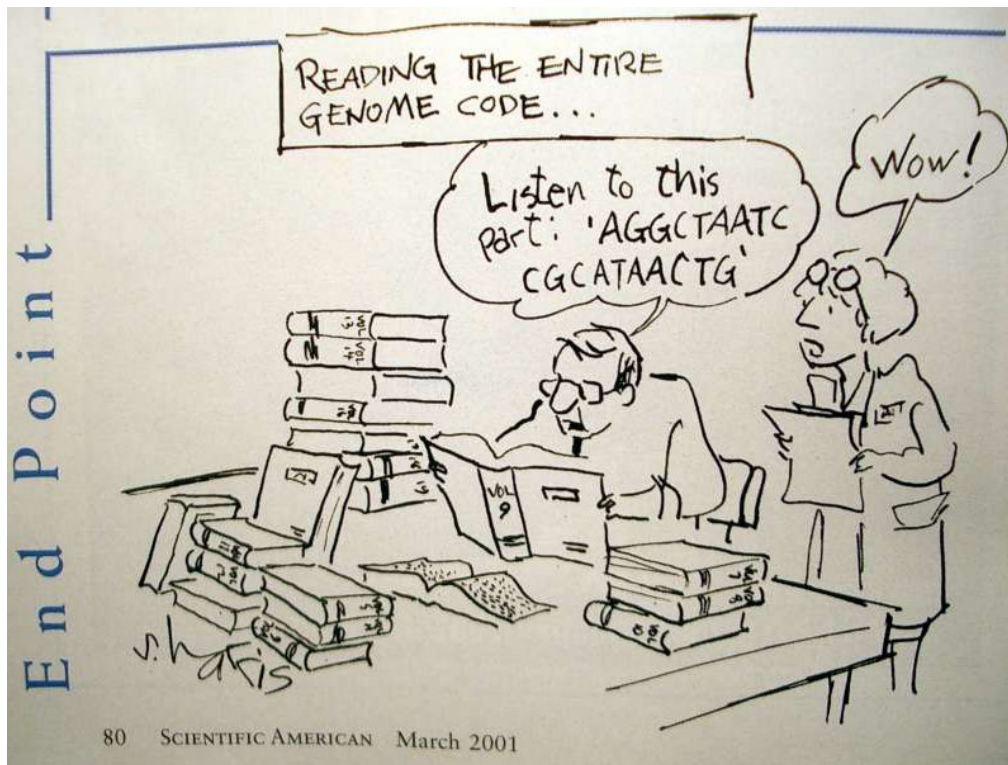

**Q:** "The data are accumulating and the computers are humming, what we are lacking are **the words, the grammar and the syntax of a new language...**"

D. Bray (TIBS 22(9):325-326, 1997)

**A:** "The most advanced tools for computer process description seem to be also the best tools for the description of biomolecular systems."

E.Shapiro (Lecture Notes)

# References

[MCB] Molecular Cell Biology, Freeman.

[MBC] Molecular Biology of the Cell, Garland.

[Ptashne] A Genetic Switch.

[Davidson] Genomic Regulatory Systems.

[Milner] Communicating and Mobile Systems: the Pi-Calculus.

[Regev] Computational Systems Biology: A Calculus for Biomolecular Knowledge (Ph.D. Thesis).

## Papers

### *BioAmbients*

a stochastic calculus with compartments.

### *Brane Calculi*

process calculi with computation "on" the membranes, not inside them.

### *Bitonal Systems*

membrane reactions and their connections to "local" patch reactions.

### *Abstract Machines of Systems Biology*

the abstract machines implemented by biochemical toolkits.

[www.luca.demon.co.uk/BioComputing.htm](http://www.luca.demon.co.uk/BioComputing.htm)